

# Keysight M9216A PXI High Voltage Data Acquisition Module

32-Channel, 250 kS/s, 16-bit, 5 V/100 V

## Introduction

The Keysight Technologies, Inc. M9216A is a multi-channel, large-range voltage measurement unit capable of acquiring dynamic positive voltage levels from multiple channels simultaneously, making it ideal for automated test equipment (ATE) in automotive electronics applications.



## Product description

The M9216A is a two slot, PXI-based, high voltage data acquisition module with a 16-bit resolution that allows simultaneous measurement of 8 channels of positive voltages ranging from 1 mV to 100 V. Each channel in the module comes with a concurrent 5 V and 100 V measurement range instead of having multiple switchable voltage ranges. This allows each channel to acquire signals that fluctuate between very low and very high voltage levels without the need for switching ranges and doing separate measurements.

The M9216A module also comes with a built-in 32 to eight multiplexer, enabling 32 measurement ports to be connected to the eight acquisition channels expanding it to a full blown 32 channel acquisition module. Alternatively, these channels can also be routed out via auxiliary output connector J101 eliminating the need for external multiplexers and pin matrix cards for additional measurements.

With the support of up to 32 channels with each channel equipped with dual concurrent measurement ranges, the M9216A module is capable of doing fast parallel voltage level measurements with guaranteed accuracy. This is ideal for the automotive industry and since most automotive applications do not require negative voltage measurements, the M9216A's 16-bit ADC is fully used for positive voltages giving it better resolution hence better accuracy.

## Application

- Automotive

## Features

- 16-bit resolution
- 32 channels
- Dual concurrent voltage ranges for each channel:
  - > 5 V (1 mV to 5 V)
  - > 100 V (20 mV to 100 V)
  - Input accuracy at 5 V
  - > zero offset : 5 V range – 200  $\mu$ V, 100 V range – 1 mV
  - > gain (% of reading): 5 V range – 0.05%, 100 V range – 0.05%
  - > noise @ 3 sigma: 5 V range – 200  $\mu$ V, 100 V range – 2 mV
- Auxiliary outputs for additional measurements
- Connector compatibility with cPCI, PXI-H, PXI-1
- Included drivers: IVI-COM, IVI-C, LabVIEW G



## Customer values

- High-channel count for fast and accurate acquisition of multiple voltage levels and doing parallel testing
- Concurrent dual range for each channel to support large voltage range without the need for switching ranges
- Auxiliary output for additional measurements

## Easy Setup, Test, and Maintenance

### Hardware platform

### Compliance

The M9216A data acquisition module is PXI compliant, using either a cPCI, PXI-1 or PXI Hybrid slot. The product can be integrated with other test and automation modules in cPCI, PXI-1 and PXI-H chassis (hybrid slots). The PXI format offers high performance in a small, rugged package. It is an ideal deployment platform for many automated test systems. A wide array of complementary PXI products is currently available. Products include multimeters, waveform generators, local oscillators, digitizers, down converters and switch multiplexers.

## Input range

The M9216A comes with a large input range with dual concurrent measurement range of 5 V and 100 V for each channel. The 5 V range caters for voltage levels of 1 mV to 5 V while the 100 V range caters for voltage levels of 20 mV to 100 V, enabling every channel to acquire voltage levels ranging from 1 mV to 100 V without the need for switching ranges, making it ideal for fast measurement needs.

## Measurement channels & auxiliary outputs

The built-in 32 to eight multiplexer is constructed where each dual range acquisition channel in the M9216A is connected to four ports through a 4-to-1 multiplexer, two of the ports can also be routed out via the auxiliary output connector J101. Every eight ports connect to a one of four floating commons making it one acquisition bank as shown in Figure 1, making a total of four acquisition banks.

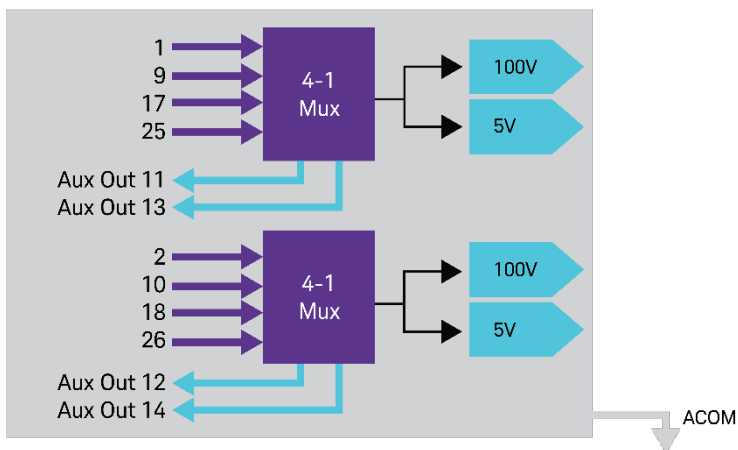

Figure 1. Example of a data acquisition bank (Bank 1)

## Software platform

### IO libraries

Keysight IO Libraries Suite offers FAST and EASY connection to instruments and the newest version extends that capability to include modular instruments.

NEW support for PXI — The Keysight IO Libraries Suite helps you display ALL of the modules in your system. From here you can view information about the installed software or start the modules' soft front panel. Launch the modules' soft front panel directly from Keysight Connection Expert.

### Drivers

The M9216A high voltage data acquisition module is supplied with a comprehensive portfolio of module drivers, documentation, examples, and software tools to help you quickly develop test systems with your

software platform of choice. The module comes with IVI-COM, IVI-C, and LabVIEW G software drivers that work in the most popular test and measurement development environments including LabVIEW and LabWindows/CVI from National Instruments, Microsoft C/C++, C#, and VB.NET

## Easy software integration

The module software support provides context sensitive help, complete documentation and code examples that allow a quick module set up and basic acquisition functionalities. These code examples can be easily modified, so that the card can be quickly integrated into a test system. Included are application code examples for LabVIEW, LabWindows/CVI, Visual Studio C, C++, and C# and Visual Basic.

## Technical Specifications

Voltage input input (general)	
Number of Channels	8 concurrent dual range channels
Resolution	16 bit
Sampling rate	250 kS/s
Analog bandwidth (anti-aliasing filter)	85 kHz
Dual range specifications	
5 V	1 mV to 5V
100 V	20 mV to 100 V
Input coupling	DC
Input impedance	550 k $\Omega$ (typical)
Internal sample memory	30,000 samples for 5 V and 100 V range per channel (multiple mode)
	240,000 samples for 5 V and 100 V range for one channel (single mode)
Trigger	Software and digital trigger Pre and post trigger sample acquisition Timed delay
Voltage input input accuracy (at 25 + 3° C)	
5 V Range	
Zero offset	$\pm 200 \mu\text{V}$
Gain (% of reading)	$\pm 0.05\%$

Noise 3 sigma	200 $\mu$ V
<b>100 V Range</b>	
Zero offset	1 mV
Gain (% of reading)	0.05%
Noise 3 sigma	2 mV

### Multiplexer

Input channels	32
Output channels	8 channels to ADC
	8 channels to primary auxiliary out
	8 channels to complementary auxiliary out
Maximum input voltage	100 V
Maximum input current	0.5 A
Maximum common return pin voltage with respect to chassis ground	45 V

### Power

Maximum current consumption from PXI	
5 V	0.8 A
3.3 V	0.5 A
Maximum input voltage	100 V
Maximum input current	0.5 A
Maximum common return pin voltage with respect to chassis ground	45 V
Warm up time	0.5 hour

NOTE: A minimum system warm up time of 15 minutes is required. For optimum accuracy, a warm up time of one hour is recommended.

## General Specifications

### Environmental and physical

Operating temperature	0 to 55° C
Storage temperature	-20° C to 70° C

Relative humidity	0% to 80% non condensing
Dimensions	3U, 2-slot, PXI/cPCI module; 40.30 mm x 129.11 mm x 212.73 mm (1.59 in. x 5.08 in. x 8.38 in.)
Weight	0.51 kg (1.12 lb)
Certifications and Compliance	Altitude : 10,000 ft (Operating)/ 15,000 ft (Non-operating)
CE Mark Compliance	2006/95/EC; 2004/108/EC
Safety	Pollution Degree 2
EMC Immunity	EN/IEC 61326-1 Industrial Environment
EMC Emissions	EN/IEC 61326-1 Class A

## Definitions for specifications

Specifications describe the warranted performance of calibrated instruments that have been stored for a minimum of 2 hours within the operating temperature range of 0 to 50°C, unless otherwise stated, and after a 45 minute warm-up period. Data represented in this document are specifications unless otherwise noted.

Characteristics describe product performance that is useful in the application of the product, but that is not covered by the product warranty. Characteristics are often referred to as Typical or Nominal values. Characteristic are represented in italics.

- Typical describes characteristic performance, which 80% of instruments are expected to meet when operated over a 20 to 30 °C temperature range. Typical performance is not warranted.
- Nominal describes representative performance that is useful in the application of the product when operated over a 20 to 30 °C temperature range. Nominal performance is not warranted.

Note: All graphs contain measured data from several units at room temperature unless otherwise noted

## Configuration and Ordering Information

### Ordering Information

Model	Description
M9216A	M9216A PXI High voltage data acquisition, 32-channel, 250KS/S, 16-BIT, 100 V input

### Accessories

M9216A-CD1	Software and product information on CD
------------	--

## Software

In addition, the M9216A includes a soft front panel graphical interface. This simple software application can be used to

- Enable verification that the modules are properly installed and working in the system.
- Assist in learning the module capability and behavior via interactive use.
- Assist in acquiring programming knowledge of the instrument.
- Assist in the verification and debugging of the system.



Model	Description
Keysight IO Libraries	Keysight IO Libraries Drivers, soft front panels and programming examples in LabVIEW, LabWindows/CVI, Visual Studio C, C++ and C#, Visual Basic, and MATLAB

1. For the M9216A to work properly, at least one PXI chassis and one PXI controller type must be available.
2. Keysight IO Libraries Suite 16.0 is required. The modular product won't work with Keysight IO Libraries Suite versions earlier than version 16.0.

## Calibration intervals

The M9216A is factory calibrated and shipped with a calibration certificate.

Calibration is recommended every year in order to verify product performance.

Learn more at: [www.keysight.com](http://www.keysight.com)

For more information on Keysight Technologies' products, applications or services, please contact your local Keysight office. The complete list is available at: [www.keysight.com/find/contactus](http://www.keysight.com/find/contactus)

