

# M9260A PXIe Audio Analyzer Module

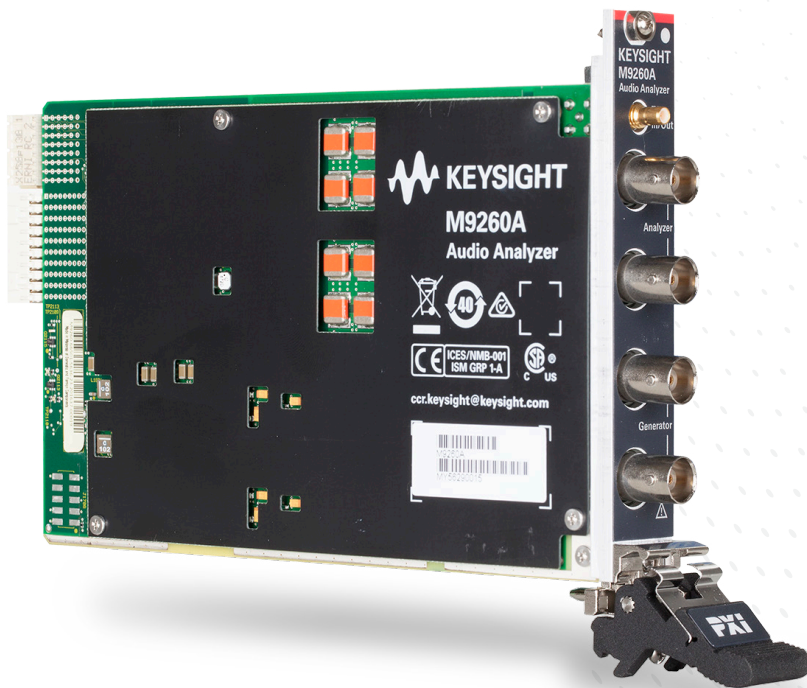

## What is an Audio Analyzer?

An audio analyzer is a test and measurement instrument that is used to quantify the audio quality of electronic and electro-acoustical devices, including but not limited to the following:

- Radio
- Mobile phone
- *Bluetooth*<sup>®</sup> audio device
- Broadcasting system
- Home theater
- Speaker
- Microphone
- ADC/DAC
- Audio/Low-frequency amplifier
- Automotive infotainment system
- Hearing aid

Typically, audio quality metrics comprise the level gain, total harmonic distortion (THD), total harmonic distortion plus noise (THD+N), crosstalk, relative phase of signals and frequency response, among others.

The three important characteristics in the selection of an audio analyzer. It's cost and technically difficult to improve these characteristics.

- **Purity of signal generation:** How certain are you that the signal received by the DUT is the signal generated by the audio analyzer?
- **The residual total harmonic distortion and noise (THD+N):** If your device under test has excellent performance it will just generate very low noise and distortion. To test your device you need an audio analyzer with very residual low THD+N.
- **Test speed:** How fast can the audio analyzer test multiple device under tests (DUTs) in the production line?

## The M9260A PXIe Audio Analyzer is Not your Traditional Digitizer

The Keysight Technologies, Inc. M9260A PXIe audio analyzer module is designed for fast, high-performance audio measurement, unlike traditional general-purpose digitizers.

The M9260A build includes two audio generator channels and two audio analyzer channels in a single 3U height PXIe module.

Key features that make the M9260A uniquely fast and accurate include:

- **Large 1-million-sample arbitrary waveform buffer** that speeds up signal generation
- **Large 1-million-sample input buffer** that speeds up signal acquisition and analysis
- **Gain of 5 amplifiers** that increase signal sensitivity, leading to accurate replication of signals to and from the DUT
- Super-linear, low-noise analog-to-digital converters (ADC) and digital-to-analog converters (DAC)
- Signal generation with ultra-low residual distortion of -106 dB and 1% amplitude accuracy

Additional built-in features of the M9260A PXIe audio analyzer that make it a worthy investment:

- **Built-in loopback system** helps with self-calibration of the “generator” and “analyzer” blocks, hence ensuring the quality and accuracy of signal used for test
- **Built-in multiple impedance selection** allows convenient impedance matching to avoid errors due to mismatched impedances in the test system

## Pure Audio Signal Generation

A pure or clean audio signal is defined by a signal with very low distortion and noise. One of the common contributors to signal distortion in traditional digitizers is phase discontinuity. Traditional digitizers typically come with relatively small arbitrary waveform buffers that can only house a maximum of 1K to 2K samples. For complex test signals that exceed this capacity, usually several hundred thousand samples, the signal needs to be 'chopped' up into multiple pieces and then 'stitched back' together to recreate the entire waveform. The 'stitching back' is where phase discontinuity inevitably happens. With the M9260A PXIe audio analyzer module, you can transmit up to 1 million samples of signal all at once, owing to its large arbitrary waveform buffer, which avoids the issue of distortion due to phase discontinuity.

Distortion in audio signal generation can also be caused by the non-linearity of output amplifiers. Typically, this can be resolved by using an amplifier with a higher gain. While a traditional digitizer module typically has only three ranges (gain of 3), the M9260A PXIe audio analyzer module has five, resulting in an output that's relatively more linear and accurate. With the M9260A, you can achieve:

- **THD+N (20 Hz to 20 kHz):** -103 dB ( $\geq 1$  Vp)
- **THD (20 Hz to 20 kHz):** -106 dB
- **Amplitude accuracy:**  $\pm 0.087$  dB ( $\pm 1\%$ )

## High-Performance Audio Measurement

Leveraging the design of the high performance Keysight U8903B audio analyzer, the M9260A PXIe audio analyzer module provides reliable audio measurement capabilities that matches its pure signal generation.

- **Amplitude accuracy:**  $\pm 0.58\%$  for AC,  $\pm 1\%$  for DC
- **Low input residual distortion and noise:** -95 dB at 1 kHz, 20 Hz to 20 kHz BW
- **Residual THD:** -101 dB at 1 kHz, 20 Hz to 20 kHz BW
- **Max input amplitude:** 46 Vp
- **Flatness:**  $\pm 0.08$  dB (20 Hz to 88 kHz BW,  $\leq 10$  Vp)
- **Ultra-low crosstalk for multi-channel measurement:** -123 dB (20 kHz BW)

# High-Speed Production Testing

In high-throughput production testing, speed is critical. The M9260A PXIe audio analyzer module is designed to optimize testing speed in two ways: fast signal generation and fast signal analysis. Figure 1 illustrates the blocks within the M9260A that define its unique high-throughput capability.

## Fast audio signal generation

There are two ways for a signal to be generated by the M9260A. The first method is to have the test signal created via the PC software and then loaded to the M9260A arbitrary waveform buffer. The M9260A PXI module then generates the test signal according to the arbitrary waveform description, to the Device Under Test (DUT).

### Large 1-million-sample arbitrary waveform buffer

Traditional digitizers typically come with relatively small arbitrary waveform buffers that can only house a maximum of 1K to 2K samples. For complex test signals that exceed this capacity, usually several hundred thousand samples, the signal needs to be first 'chopped' up into multiple pieces, and then sequentially sent to the PXIe module. The total processing time can be significantly reduced with the M9260A PXIe audio analyzer module, as it comes with a large 1-million-sample arbitrary waveform buffer. This means you can transmit any waveform of up to 1 million samples, to the M9260A module once, without having to face buffer and speed limitations that are common with traditional digitizers.

### Built-in waveforms

In addition to the large arbitrary waveform buffer, Figure 1 also shows that the M9260A PXIe audio analyzer module comes with built-in waveforms that speed up the signal generation process further. Commonly used waveforms that are built into the M9260A include the sinewave, dual-sinewave, variable-phase sinewave, DC, Gaussian noise, rectangular noise and pink noise. Having these waveforms built in means you do not need to generate the test signal with a PC software. All you need to do is send a software command to the PXIe module and indicate which of the built-in waveforms you would like to generate. The PXIe module then sends the signal almost immediately to the DUT, reducing significant signal generation time.

## Fast audio signal analysis

For signal measurement, the M9260A receives the incoming test signal from the DUT, after which the signal goes through signal conditioning and the analog-to-digital converter before it is sent to the input buffer where the signal 'waits' to be streamed back to the PC for analysis.

### Large 1-million-sample input buffer

As with its large arbitrary waveform buffer for signal generation, the M9260A PXIe audio analyzer has a large 1-million-sample input buffer, which means a virtually 'limitless' memory for acquisition and seamless streaming to PC. This is unlike traditional digitizers that typically provide a smaller 1K input buffer size that limits the signal measurement capability to just 1 thousand samples at any one time. With the M9260A module, you can achieve fast audio signal acquisition and analysis for high-speed production testing.

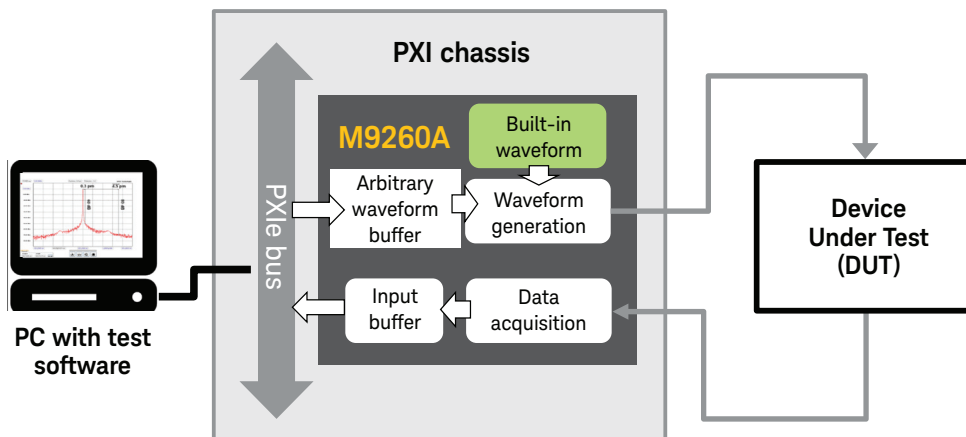

Figure 1. M9260A PXIe audio analyzer signal generation and acquisition building blocks

## Loopback and Multiple Impedance Selection

The M9260A PXIe audio analyzer module includes built-in features that aim to provide you with greater convenience and confidence in your audio measurement tasks. Figure 2 illustrates the loopback and multiple impedance selection within the M9260A.

**Loopback:** The M9260A module has a loopback from the generator to the analyzer. This enables an automatic self-test and self-calibration of the audio analyzer module. This avoids the need for manual calibration via an external BNC cable, which could inevitably introduce errors due to the external connector or cable. For automated test systems, the loopback is a critical feature as manual calibration via an external BNC cable is not an allowed procedure.

**Multiple impedance selection:** Unmatched impedances can create errors in test, which is why it is necessary to ensure exact impedance matches to the DUT. Typical digitizers do not provide a selection of impedances – usually only one – hence you often need to use external impedance converters to achieve the required impedance. The M9260A output impedance selection includes the 50  $\Omega$  impedance that's commonly used for audio devices, and 600  $\Omega$  impedance to match legacy audio devices. The M9260A input impedance includes three selections: 50  $\Omega$ , 600  $\Omega$ , and 1 M $\Omega$  to match the output of most audio devices. In addition to this selection, the Keysight U8903A-109 BNC accessory kit is available if you need to convert the M9260A impedance to any other required value.

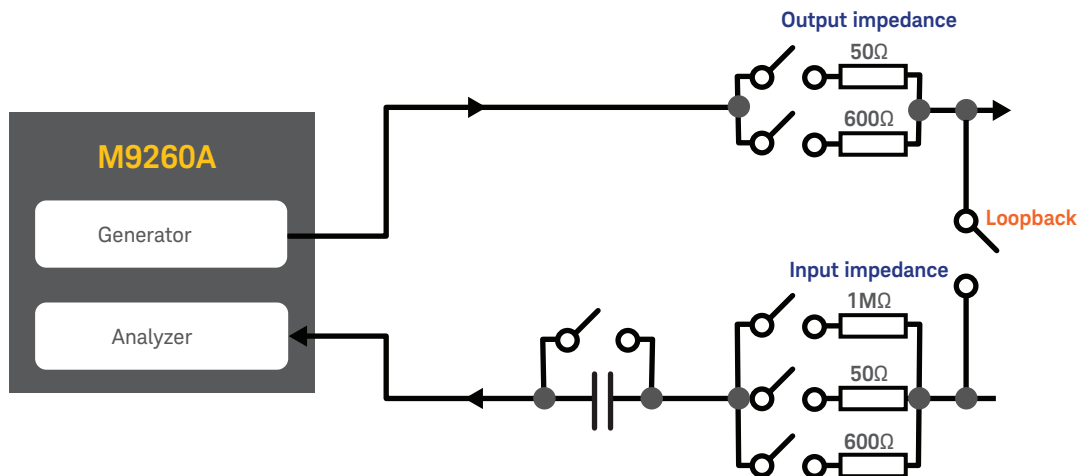

Figure 2. M9260A PXIe audio analyzer loopback and multiple impedance selection features

# The M9260A PXIe Audio Analyzer for your Radio Testing

## Keysight radio test solution

The M9260A PXIe audio analyzer module is a critical part of the Keysight Radio Test Solution, specifically in the audio signal generation and analysis. The Keysight Radio Test Solution is a combination of hardware and software building blocks in a single, scalable chassis, aimed at providing military, public safety, and avionics radio communication departments with reliable, quality RF and audio signal generation and analysis.

More info on the Keysight Radio Test Solution: <https://www.keysight.com/en/pc-2903302/radio-test-solutions?nid=-31942.0.00&cc=US&lc=eng>

## BG1000A Audio Measurement Library

The Keysight BG1000A Audio Measurement Library provides powerful audio analysis functions for software developers. It allows users to perform complex audio measurements using data captured from Audio Analyzer, Digitizer and other hardware. It enables fast and easy software development of any applications which require audio analysis.

Benefits:

- Easily implement complex audio measurements by just calling the measurement functions included in the BG1000A Audio Measurement Library without the need to worry about the computation details.
- This audio measurement library is not tightly coupled with any hardware. The library should be able to be used by any party that need this measurement functions
- Shorten the development time and get quality results sooner.
- Multiple SINAD acquisitions from a single command allow custom averaging algorithm application for sensitivity measurements.
- Supporting various software development environment such as Visual C#, Visual C++, Keysight VEE, Labview.

More info on the BG1000 Audio Measurement Library: [www.keysight.com/find/BG1000A](http://www.keysight.com/find/BG1000A)

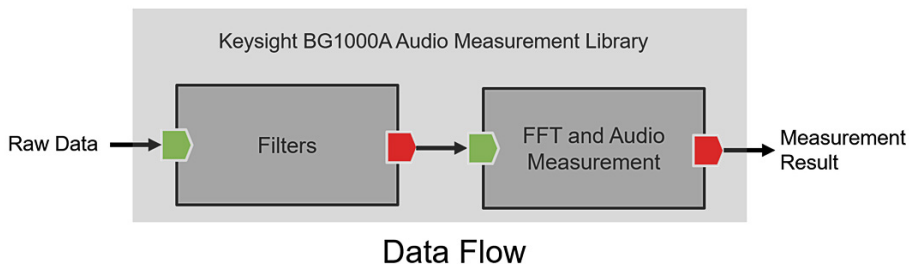

Figure 3. BG1000A data flow in an audio signal processing and analysis

## Software: Drivers and Soft Front Panel (SFP)

Included in the M9260A software installer that you can [download from Keysight.com](https://www.keysight.com) are the IVI-C, IVI-COM and LabVIEW G drivers. Also included in the installer is the intuitive M9260A PXIe module soft front panel (SFP) software that you can use to configure and control the PXIe module.

SFP features:

- Module maintenance allows self-test, module reset and firmware upgrades
- Audio generator settings allow sine-wave generation, with amplitude frequency and DC offset adjustments. You can also select differential or pseudo-differential output, and 50  $\Omega$  or 600  $\Omega$  output impedance
- Audio analyzer settings allow loopback control, and selection of differential or pseudo-differential input, AC or DC input coupling, and 50  $\Omega$ , 600  $\Omega$  or 1 M $\Omega$  input impedance.
- Basic audio measurements: AC voltage, DC voltage, frequency, THD+N ratio, THD ratio, SINAD and SNR
- Filter options: 20 kHz low-pass filter, 20 Hz high-pass filter, A-weight filter or no filter

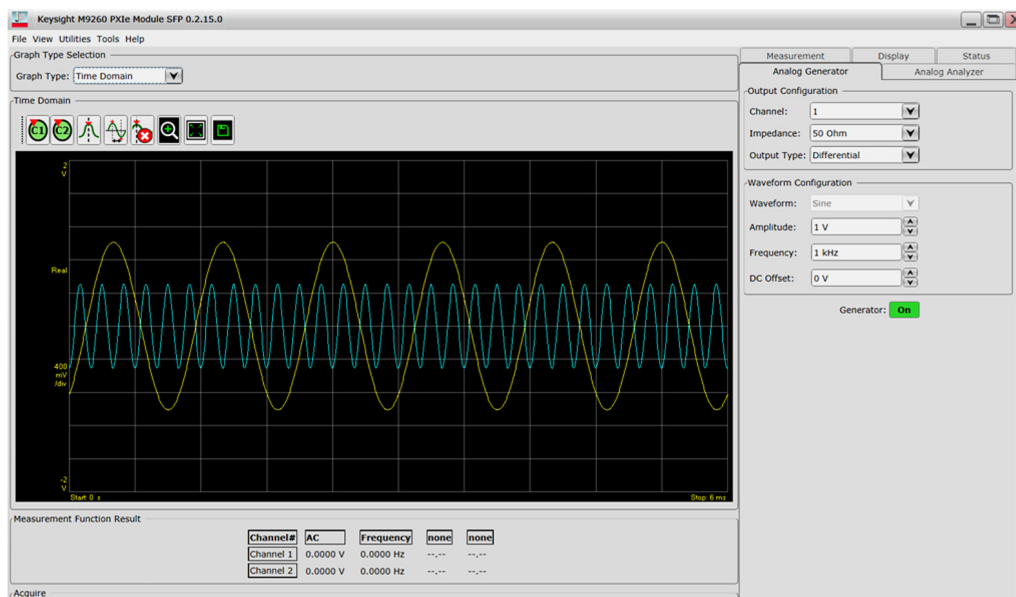

Figure 4. M9260A PXIe module soft front panel interface

## Product Characteristics

Description	
<b>Operating environment</b>	
Operating temperature	0 to 55 °C
Storage temperature	-40 to 71 °C
Operating humidity	Up to 95% RH at 40 °C (non-condensing)
Storage humidity	Up to 90% RH at 65 °C (non-condensing)
Operating altitude	Up to 3000 m
Non-operating altitude	Up to 4600 m
Other	Meets or exceeds Keysight ETM requirements on class GP where applicable. These include EMC, ESD, shock and vibration, power tolerances from PXI chassis, etc.
Form factor	Type/dimension: PXIe, 1 slot, 3U
Calibration period	1 year
Drivers	Support and complies with Keysight CCE requirements for PXI modular: IVI-COM, IVI-C, LabVIEW
<b>Trigger - Digital</b>	
Trigger connector	SMB male
Trigger level	3.3 V TTL
Polarity	Rising or falling edge
Trigger source	External trigger input (available at front panel), PXI trigger bus
Pulse width	Min 10 µs
<b>Trigger - Analog</b>	
Trigger connector	SMB male
Trigger level	± full-scale
Polarity	Rising or falling edge
Resolution	24 bits



## Performance Specifications

The following specifications are based on performance following 30 minutes of warm-up time and at operating temperatures between 0 °C to 55 °C, and sample rate of 192 kS/s unless stated otherwise.

Analog generator specifications	
Connector type	BNC
Impedance	50 Ω, 600 Ω (nom)
Input configuration	Differential, pseudo-differential (50 Ω connected from negative input to chassis ground)
Number of output channels	2 channels per module
Built-in waveform	Sine, Dual Sine, Variable Phase, Gaussian Noise, Rectangular Noise, Pink Noise
Dual sine amplitude ratio	0% to 100%
Variable phase	-180° to 179.99°
Sample rate (fs)	1.024 kS/s to 204.8 kS/s (363.8 μHz resolution)
Arbitrary waveform buffer	Max 1,048,576 samples/download
DAC resolution	24 bits
Max output amplitude	10 Vp
Output range	0.1 Vp, 0.316 Vp, 1 Vp, 3.16 Vp, 10 Vp in 10 dB steps
Max output current	50 mA (nom)
DC accuracy	± 1% (-0.087 dB to 0.086 dB) ± 0.32% (± 0.028 dB) (typ)
AC accuracy at 1 kHz	± 1% (-0.087 dB to 0.086 dB) ± 0.4% (± 0.035 dB) (typ)
AC flatness (refer to 1 kHz)	
– 5 Hz to 20 kHz BW	
– At 0.1 Vp	± 0.2500% (± 0.0217 dB) ± 0.1440% (± 0.0125 dB) (typ)
– At 0.316 Vp, 1 Vp, 3.16 Vp	± 0.0925% (± 0.008 dB) ± 0.0560% (± 0.0049 dB) (typ)
– At 10 Vp	± 0.1% (± 0.0087 dB) ± 0.0560% (± 0.0049 dB) (typ)
– 20 kHz to 80 kHz BW	± 0.9250% (-0.081 dB to 0.080 dB)
– All ranges	± 0.64% (± 0.055 dB) (typ)
Residual THD+N (at 1 kHz)	
– 20 Hz to 20 kHz BW	
– At 0.316 V	< 0.0017% (< -95 dB) < 0.0012% (< -98.4 dB) (typ)
– At 1 Vp, 3.16 Vp, 10 Vp	< 0.0007% (< -103 dB) < 0.00056% (< -105 dB) (typ)
Residual THD (at 1 kHz)	
– 20 Hz to 20 kHz BW	
– At 0.316 Vp, 1 Vp, 3.16 Vp, 10 Vp	< 0.0005% (< -106 dB) (typ) < 0.00036% (< -108.9 dB) (typ)
Frequency range (fs = 192 kS/s)	5 Hz to 79.8 kHz (up to 0.416 Fs)
Frequency accuracy <sup>1</sup>	± 2 ppm + 100 μHz

Note: The voltage levels indicated in the specifications are at the full-scale of each respective range.

1. Stated frequency accuracy specification is achievable depending on the PXI chassis 10 MHz system clock accuracy or the applied external clock reference accuracy.

<b>Analog analyzer specifications</b>	
Connector type	BNC
Impedance	50 Ω, 600 Ω, 1 MΩ (nom)
Input coupling	AC, DC
Number of input channels	2 channels per module
Sample rate	1.024 kS/s to 204.8 kS/s (363.8 μHz resolution)
Acquisition buffer	Max 1,048,576 samples/acquisition
ADC resolution	24 bits
Measurement bandwidth	90 kHz at 192 kS/s (up to 0.47 SR)
Max input amplitude	46 Vp
Input range	0.316 Vp, 1 Vp, 3.16 Vp, 10 Vp, 31.6 Vp, 46 Vp in 10 dB steps
Input protection	Overload protection for all ranges, with overload status registers (each channel) that enables the software to be informed of the overload status
DC accuracy	± 1% (-0.087 dB to 0.086 dB) ± 0.24% (± 0.021 dB) (typ)
AC accuracy	± 0.58% (± 0.05 dB) ± 0.12% (± 0.010 dB) (typ)
AC flatness (ref to 1 kHz)	
– 10 Hz to 20 kHz BW	
– At 0.316 Vp	± 0.13% (± 0.011 dB) ± 0.072% (± 0.0062 dB) (typ)
– At 1 Vp, 3.16 Vp, 10 Vp	± 0.0925% (± 0.008 dB) ± 0.056% (± 0.0049 dB) (typ)
– At 31.6 Vp, 46 Vp	± 0.8000% (-0.07 dB to 0.069 dB) ± 0.32% (± 0.0278 dB) (typ)
– 20 kHz to 88 kHz BW	
– At 0.316 Vp, 1 Vp, 3.16 Vp, 10 Vp	± 0.9250% (-0.081 dB to 0.080 dB) ± 0.520% (± 0.045 dB) (typ)
– At 31.6 Vp, 46 Vp	± 5.2000% (-0.46 dB to 0.44 dB) ± 3% (-0.26 dB to 0.257 dB) (typ)
Residual THD+N (at 1 kHz)	
– 20 Hz to 20 kHz BW	
– At 0.316 Vp	< 0.0017% (< -95 dB) < 0.00136% (< -97 dB) (typ)
– At 1 Vp, 3.16 Vp, 10 Vp	< 0.00085% (< -101 dB) < 0.00068% (< -103.3 dB) (typ)
Residual THD (at 1 kHz)	
– 20 Hz to 20 kHz BW	
– At 0.316 Vp, 1 Vp, 3.16 Vp, 10 Vp	< 0.00085% (< -101 dB) < 0.00048% (< -106 dB) (typ)
Residual noise (at 0.316 Vp)	
– 20 Hz to 20 kHz BW	≤ 1.3 μVrms

Note: The voltage levels indicated in the specifications are at the full-scale of each respective range.

# Performance Characteristics

## Generator output characteristics

Crosstalk	
- 100 Hz to 20 kHz	
- At 0.316 Vp, 1 Vp, 3.16 Vp, 10 Vp	< 0.00136% (< -97.3 dB) (typ)
SMPTE IMD	
- $\leq$ 20 kHz BW	< 0.002% (< -94 dB) (typ)
DFD (IEC60118 / IEC60268)	
- $\leq$ 20 kHz BW	< 0.0008% (< -101.9 dB) (typ)
Phase offset	
- $\leq$ 20 kHz	$\pm 2^\circ$ (typ)
- 20 kHz to 80 kHz	$\pm 5^\circ$ (typ)

## Analyzer input characteristics

Crosstalk	
- $\leq$ 20 kHz	
- At 0.316 Vp	< 0.000064% (< -123 dB) (typ)
- At 1 Vp	< 0.0000253% (< -131 dB) (typ)
- At 3.16 Vp, 10 Vp	< 0.0000142% (< -136 dB) (typ)
- At 31.6 Vp, 46 Vp	< 0.0000142% (< -136 dB) (typ)
SMPTE IMD	
- $\leq$ 20 kHz BW	< 0.0036% (< -88 dB) (typ)
DFD (IEC60118 / IEC60268)	
- $\leq$ 20 kHz BW	< 0.0008% (< -102 dB) (typ)
CMRR	
- $\leq$ 20 kHz BW, $\leq$ 10 Vp	> 70 dB (typ)
Phase accuracy (at 1 Vp)	
- $\leq$ 20 kHz	$\pm 0.15^\circ$ (typ)
- 20 kHz to 90 kHz	$\pm 0.6^\circ$ (typ)

Note: The voltage levels indicated in the specifications are at the full-scale of each respective range.

## Definitions

### Specification (spec)

The warranted performance of a calibrated instrument that has been stored for a minimum of 2 hours within the operating temperature range of 0°- 55°C and after a 30-minute warm up period. All specifications include measurement uncertainty and were created in compliance with ISO-17025 methods. Data published in this document are specifications (spec) unless otherwise noted.

### Typical (typ)

The characteristic performance, which 80% or more of the manufactured instruments will meet. This data is not warranted, does not include measurement uncertainty, and is valid only at room temperature (approximately 23°C).

### Nominal (nom)

The mean or average characteristic performance, or the value of an attribute that is determined by design such as a connector type, connector impedance, physical dimension, or operating speed. This data is not warranted and is measured at room temperature (approximately 23°C).

## Ordering Information

Product model	Description
M9260A-STD	PXIe audio analyzer, 2 channels
M9260A-UDF	PXIe audio analyzer for US Defense Force, 2 channels
Optional accessories	Description
U8903A-101	Male BNC to male BNC cable, 1.2 m, jade gray
U8903A-102	Male BNC to male RCA cable, 2 m, black
U8903A-109	BNC accessory kit
M9260A-101	Trigger cable, 1 m SMB female to BNC male, 50 $\Omega$
M9260A-102	Trigger cable, 1 m SMB female to BNC female, 50 $\Omega$
Service	Description
M9260A-1A7	Calibration + Uncertainties + Guardbanding (not accredited)
M9260A-A6J	ANSI Z540-1-1994 calibration

## Related Products

Product model	Description
BG1000A	Audio measurement library
U8903B	Performance audio analyzer, 2 channels
U8903A	Audio analyzer, 2 channels, discontinued on December 31, 2016

Learn more at: [www.keysight.com](http://www.keysight.com)

For more information on Keysight Technologies' products, applications or services, please contact your local Keysight office. The complete list is available at: [www.keysight.com/find/contactus](http://www.keysight.com/find/contactus)

