

Installation Instruction

IT9120 Series Power Meter

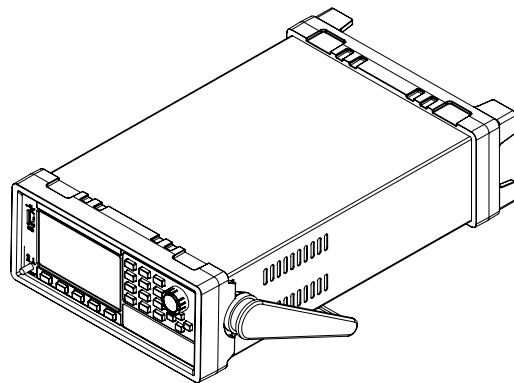

Model: IT9121/IT9121H/IT9121C

Version: V3.1

Notices

© Itech Electronic, Co., Ltd. 2020
No part of this manual may be reproduced in any form or by any means (including electronic storage and retrieval or translation into a foreign language) without prior permission and written consent from Itech Electronic, Co., Ltd. as governed by international copyright laws.

Manual Part Number

IT9120-402147

Revision

3rd Edition: Feb 28, 2020
Itech Electronic, Co., Ltd.

Trademarks

Pentium is U.S. registered trademarks of Intel Corporation.

Microsoft, Visual Studio, Windows and MS Windows are registered trademarks of Microsoft Corporation in the United States and/or other countries and regions.

Warranty

The materials contained in this document are provided “as is”, and is subject to change, without prior notice, in future editions. Further, to the maximum extent permitted by applicable laws, ITECH disclaims all warranties, either express or implied, with regard to this manual and any information contained herein, including but not limited to the implied warranties of merchantability and fitness for a particular purpose. ITECH shall not be held liable for errors or for incidental or indirect damages in connection with the furnishing, use or application of this document or of any information contained herein. Should ITECH and the user enter into a separate written agreement with warranty terms covering the materials in this document that conflict with these terms, the warranty terms in the separate agreement shall prevail.

Technology Licenses

The hardware and/or software described herein are furnished under a license and may be used or copied only in accordance with the terms of such license.

Restricted Rights Legend

U.S. Government Restricted Rights. Software and technical data rights granted to the federal government include only those rights customarily provided to end user customers. ITECH provides this customary commercial license in software and technical data pursuant to FAR 12.211 (Technical Data) and 12.212 (Computer Software) and, for the Department of Defense, DFARS 252.227-7015 (Technical Data – Commercial Items) and DFARS 227.7202-3 (Rights in Commercial Computer Software or Computer Software Documentation).

Safety Notices

CAUTION

A CAUTION sign denotes a hazard. It calls attention to an operating procedure or practice that, if not correctly performed or adhered to, could result in damage to the product or loss of important data. Do not proceed beyond a CAUTION sign until the indicated conditions are fully understood and met.

WARNING

A WARNING sign denotes a hazard. It calls attention to an operating procedure or practice that, if not correctly performed or adhered to, could result in personal injury or death. Do not proceed beyond a WARNING sign until the indicated conditions are fully understood and met.



NOTE

A NOTE sign denotes important hint. It calls attention to tips or supplementary information that is essential for users to refer to.

Quality Certification and Assurance

We certify that IT9120 series power meter meets all the published specifications.

Warranty

ITECH warrants that the product will be free from defects in material and workmanship under normal use for a period of one (1) year from the date of delivery (except those described in the Limitation of Warranty below).

For warranty service or repair, the product must be returned to a service center designated by ITECH.















- The product returned to ITECH for warranty service must be shipped PREPAID. And ITECH will pay for return of the product to customer.
- If the product is returned to ITECH for warranty service from overseas, all the freights, duties and other taxes shall be on the account of customer.

Limitation of Warranty

This Warranty will be rendered invalid if the product is:

- Damaged resulting from customer-wired circuits or customer-supplied parts or accessories;
- Modified or repaired by customer without authorization;
- Damaged resulting from customer-wired circuits or use in an environment not designated by us;
- The product model or serial number is altered, deleted, removed or made illegible by customer;
- Damaged as a result of accidents, including but not limited to lightning, moisture, fire, improper use or negligence.

Safety Symbols

	Direct current		ON (power)
	Alternating current		OFF (power)
	Both direct and alternating current		Power-on state
	Protective earth (ground) terminal		Power-off state
	Earth (ground) terminal		Reference terminal
	Caution		Positive terminal
	Warning (refer to this manual for specific Warning or Caution information)		Negative terminal
	A chassis terminal	-	-

Safety Precautions

The following safety precautions must be observed during all phases of operation of this instrument. Failure to comply with these precautions or specific warnings elsewhere in this manual will constitute a default under safety standards of design, manufacture and intended use of the instrument. ITECH assumes no liability for the customer's failure to comply with these precautions.

WARNING

- Do not use the instrument if it is damaged. Before operation, check the casing to see whether it cracks or is not applied with sufficient plastics. Do not operate the instrument in the presence of inflammable gasses, vapors or dusts.
- Make sure to use the power cord supplied by ITECH.
- Check all marks on the instrument before connecting the instrument to power supply.
- Turn off the instrument and the operation system before connecting to the I/O terminal.
- Do not use the instrument if the detachable cover is removed or loosen.
- Do not connect the instrument to any cable or terminal block before self-testing.
- To prevent the possibility of accidental injuries, be sure to use the power adapter supplied by the manufacturer only.
- We do not accept responsibility for any direct or indirect financial damage or loss of profit that might occur when using the instrument.
- This instrument is used for industrial purposes. Do not apply this product to IT power supply system.
- Never use the instrument with a life-support system or any other equipment subject to safety requirements.

CAUTION

- Failure to use the instrument as directed by the manufacturer may render its protective features void.
- Always clean the casing with a dry cloth. Do not clean the internals.
- Make sure the vent hole is always unblocked.

Environmental Conditions



The instrument is designed for indoor use and an area with low condensation. The table below shows the general environmental requirements for the instrument.

Environmental Conditions	Requirements
Operating temperature	5°C-40°C
Operating humidity	20%-80% (non-condensation)
Storage temperature	-20°C-50 °C
Altitude	Operating up to 2,000 meters
Installation category	II
Pollution degree	Pollution degree 2

NOTE

To make accurate measurements, allow the instrument to warm up for 30 min.

Regulatory Markings

	The CE mark indicates that the product complies with all the relevant European legal directives. The specific year (if any) affixed refers to the year when the design was approved.
	The instrument complies with the WEEE Directive (2002/96/EC) marking requirement. This affix product label indicates that you must not discard the electrical/electronic product in domestic household waste.
	This symbol indicates the time period during which no hazardous or toxic substances are expected to leak or deteriorate during normal use. The expected useful life of the product is 10 years. The product can be used safely during the 10-year Environment Friendly Use Period (EFUP). Upon expiration of the EFUP, the product must be immediately recycled.

Waste Electrical and Electronic Equipment (WEEE) Directive



2002/96/EC Waste Electrical and Electronic Equipment (WEEE) Directive

This product complies with the WEEE Directive (2002/96/EC) marking requirement. This affix product label indicates that you must not discard the electrical/electronic product in domestic household waste.

Product Category

With reference to the equipment classifications described in the Annex 1 of the WEEE Directive, this instrument is classified as a "Monitoring and Control Instrument".

To return this unwanted instrument, contact your nearest ITECH office.

Compliance Information

Complies with the essential requirements of the following applicable European Directives, and carries the CE marking accordingly:

- Electromagnetic Compatibility (EMC) Directive 2014/30/EU
- Low-Voltage Directive (Safety) 2014/35/EU

Conforms with the following product standards:

EMC Standard

IEC 61326-1:2012/ EN 61326-1:2013 ¹²³

Reference Standards

CISPR 11:2009+A1:2010/ EN 55011:2009+A1:2010 (Group 1, Class A)

IEC 61000-4-2:2008/ EN 61000-4-2:2009

IEC 61000-4-3:2006+A1:2007+A2:2010/ EN 61000-4-3:2006+A1:2008+A2:2010

IEC 61000-4-4:2004+A1:2010/ EN 61000-4-4:2004+A1:2010

IEC 61000-4-5:2005/ EN 61000-4-5:2006

IEC 61000-4-6:2008/ EN 61000-4-6:2009

IEC 61000-4-11:2004/ EN 61000-4-11:2004

1. The product is intended for use in non-residential/non-domestic environments. Use of the product in residential/domestic environments may cause electromagnetic interference.
2. Connection of the instrument to a test object may produce radiations beyond the specified limit.
3. Use high-performance shielded interface cable to ensure conformity with the EMC standards listed above.

Safety Standard

IEC 61010-1:2010/ EN 61010-1:2010

Content

Quality Certification and Assurance	i
Warranty	i
Limitation of Warranty	i
Safety Symbols	i
Safety Precautions	ii
Environmental Conditions	ii
Regulatory Markings	iii
Waste Electrical and Electronic Equipment (WEEE) Directive	iii
Compliance Information	iv
Chapter1 Introduction	1
1.1 Document Information	1
1.2 Product Profile	1
1.3 Verifying the Shipment	1
Chapter2 Installing the Instrument	3
2.1 Adjusting the Handle	3
2.2 Removing the Handle	4
2.3 Rack Mounting	5
2.4 Connecting the Power Cord	5
Chapter3 Inspecting the Instrument	6
3.1 Keys on the Front Pannel	6
3.2 Rear Panel	6
3.3 Power-on Self-Test	7
3.4 Zero Calibration	9
3.5 Replacing the Fuse	9
Chapter4 Wiring the Circuit under Measurement	11
4.1 Precautions when Wiring the Circuit	11
4.2 Selection of measurement method	12
4.3 Wiring the Circuit under Measurement for Direct Input	12
4.4 Wiring the Circuit under Measurement When Using Current Sensors	14
4.5 Wiring the Measurement Circuit with VT/CT	17
4.6 Instructions of IT-E185 Fixture	19
Appendix	20
Specifications of Red and Black Test Lines	20

Chapter1 Introduction

1.1 Document Information

Installation Instructions are included in the supporting documentations of the instrument which can be accessed via the CD supplied with the instrument or ITECH official website.

Manual Title	Description
IT9120 Installation Instruction (this manual)	Explain how to inspect, install and connect the instrument.
IT9120 User Manual	Explain how to conduct measurements through front panel operations.
IT9120 Programming Guide	Introduce the communication protocol and reference commands applicable to remote operation.

1.2 Product Profile

IT9120 series Power Meter is a precision power analyzer characterized by powerful and diversified features. It is designed for clearly and correctly measuring the power and energy consumption of various electrical appliances. The maximum input voltage and current of the instrument are 1000Vrms and 50Arms; the measuring bandwidth is 100KHZ; and the measurement accuracy is 0.1%. It can meet user's various measurement demands.

By virtue of its DSP+FPGA dual-core processing architecture, IT9120 series Power Meter can rapidly and accurately calculate harmonic parameters of signals. In addition, it is equipped with USB, GPIB, RS232 and LAN communication interfaces to accommodate user's different requirements on communication. Moreover, a USB peripheral component interface is provided for user to store measurement parameters in an external storage medium.

Refer to **IT9120 User's Manual** for details of general specifications and technical specifications.



NOTE

All the machine interface diagrams in this manual are taken as an example of the IT9121 model, please refer to the corresponding machine for other models.

1.3 Verifying the Shipment

Unpack the box and check the contents before operating the instrument. If wrong items have been delivered, if items are missing, or if there is a defect with the appearance of the items, contact the dealer from which you purchased the instrument immediately. The package contents include:

Table 1-1 Checklist of Package Contents

Item	Qty.	Model	Remarks
Power Meter	x1	IT9120 series	IT9120 series include: IT9121/IT9121H/IT9121C
Power cord	x1	IT-E171/IT-E172 /IT-E173/IT-E174	User may select an appropriate power cord that matches the specifications of power socket

			used in the area. Refer to the Section 2.4 Connecting the Power Cord for details of such specifications.
USB cable	x1	-	-
Product Recycling Notices	x1	-	It presents notices on recycling of the instrument.
Packing List	x1	-	It lists all the package contents.
Ex-factory Test Report	x1	-	It is the test report of the instrument before delivery.
Test leads	x1	IT-E301-30A, IT-E301-10A	IT-E301-30A (Both are Y type terminals) IT-E301-10A (banana plug –Y type terminal)

NOTE

Upon verification of the shipment, keep the package and relevant contents thereof in a safe place. When returning the instrument for warranty service or repair, the specified packing requirements shall be met. Refer to **IT9120 User's Manual** for detailed requirements on returns.

IT9120 series Power Meter is supplied with the following optional accessories (sold separately):

Item	Model	Remarks
Rack mount kit	IT-E151/IT-E151A	To mount the instrument on a special rack, user may select this optional.
Test fixture box	IT-E185	Use IT-E185 fixture in AC input power consumption of AC-DC adapter. Refer to the Section 4.6 Instructions of IT-E185 Fixture for details of installation.
Current sensor	IT-E190	-

Chapter2 Installing the Instrument

Power Meter can be either placed directly on a desktop or mounted on the rack supplied as an optional accessory.

2.1 Adjusting the Handle

The instrument is equipped with a handle for user to easily carry and place it.

The handle can be adjusted in three manners as shown in the figure below. To adjust the handle, first pull out the handle gently toward the left and right sides of the instrument, and then rotate it slowly to its alignment keys.

Horizontal Position

Place the instrument horizontally on a desktop.

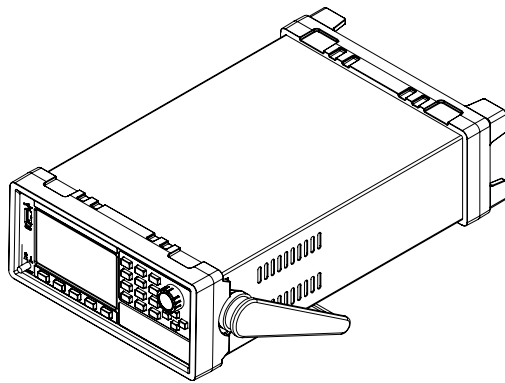

Adjusting the Position

1. Pull out the handle to a rotatable state, as shown below.

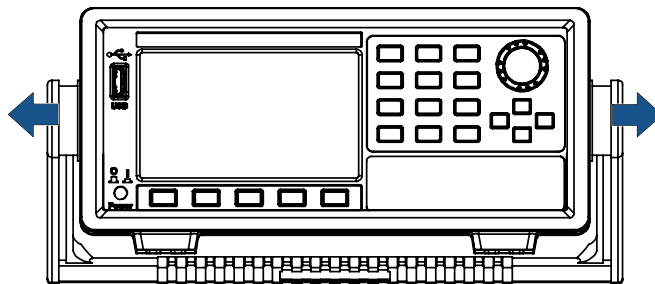

2. Rotate the handle to the desired position, as shown below.

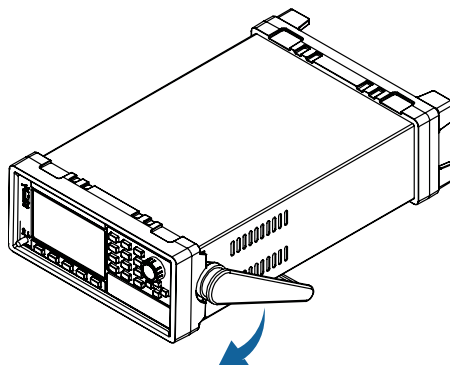

3. Place the instrument on a desktop, as shown below.

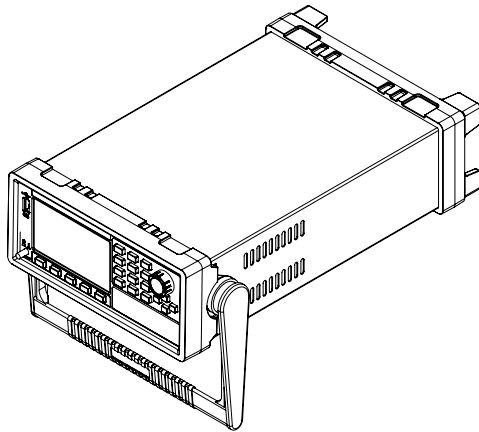

2.2 Removing the Handle

To mount the instrument on a rack, first remove the handle from the instrument.

The handle can be removed following the procedures below:

1. Pull out the handle toward the left and right sides and it can be rotated.

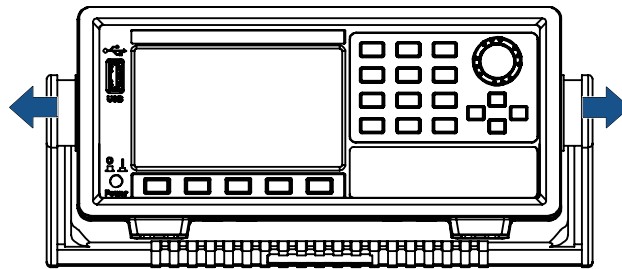

2. Rotate the handle to the position as shown in the following figure.

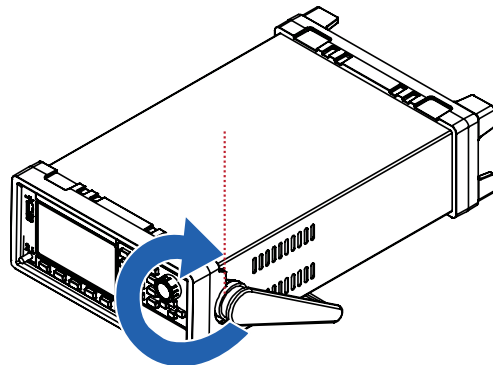

3. Pull out the handle toward the left and right sides of the instrument from the alignment hole.

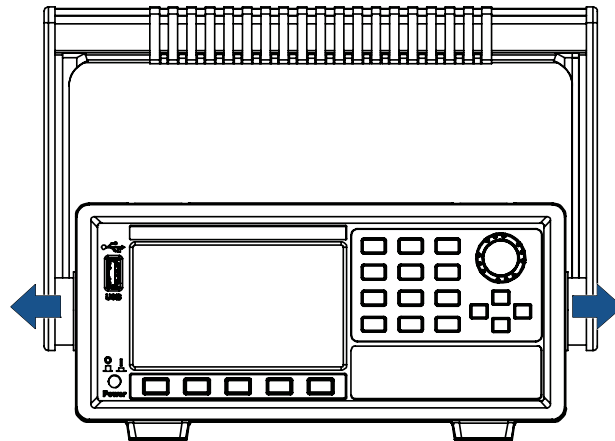
NOTE

The handle can be easily removed from the alignment hole and key between the handle and the instrument. When mounting or removing the handle, do not squeeze it too hard and mind your hand.

2.3 Rack Mounting

IT9120 series Power Meter can be mounted on a standard 19" rack. ITECH provides user with IT-E151/IT-E151A rack, an optional mount kit.

2.4 Connecting the Power Cord

Connect the power cord after checking that the power switch of the instrument is turned OFF. Only use the power cord supplied as a standard accessory. A summary of connection procedures is given below.

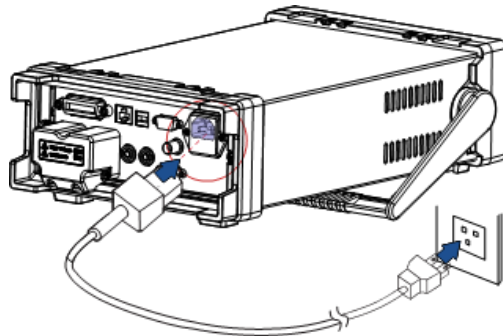

Select from the following Schedule of Power Cord Specifications an appropriate power cord that matches the voltage for the area in which you use the instrument. If the power cord included in the instrument you purchased does not match the voltage, contact the dealer or manufacturer for change.

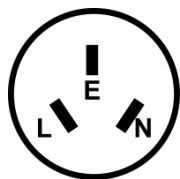

China
IT-171



America, Canada,
Japan
IT-E172

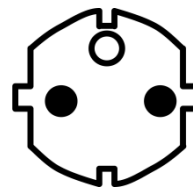

Europe
IT-E173



Britain
IT-E174

Chapter3 Inspecting the Instrument

This chapter presents you an overview of the front and rear panels and the power-on checkups that are necessary to ensure the instrument starts and functions properly under the initial conditions.

3.1 Keys on the Front Panel

The schematic diagram of front panel and key functions of IT9120 series is shown below:

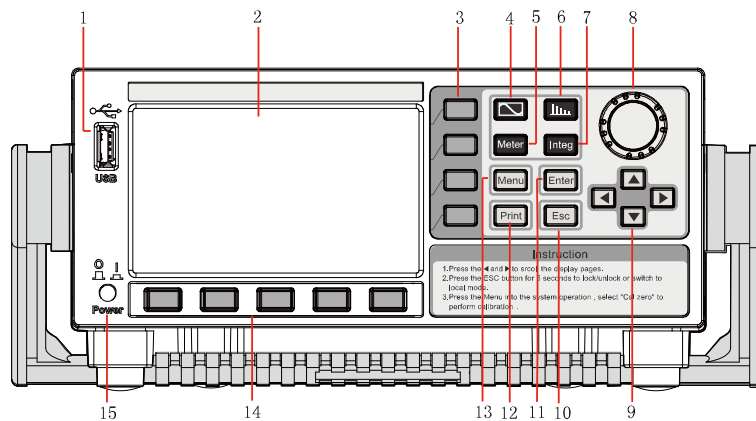

- | | | |
|------------------------|-----------------|-----------------|
| 1 USB PCI | 2 Display | 3 Menu key |
| 4 Waveform Display key | 5 Function key | 6 Harmonics key |
| 7 Integrator key | 8 Setting Knob | 9 Arrow keys |
| 10 Enter key | 11 Hold/ESC key | 12 Set key |
| 13 Image Save key | 14 Menu key | 15 Power switch |

3.2 Rear Panel

The schematic diagram of rear panel and key functions is shown below:

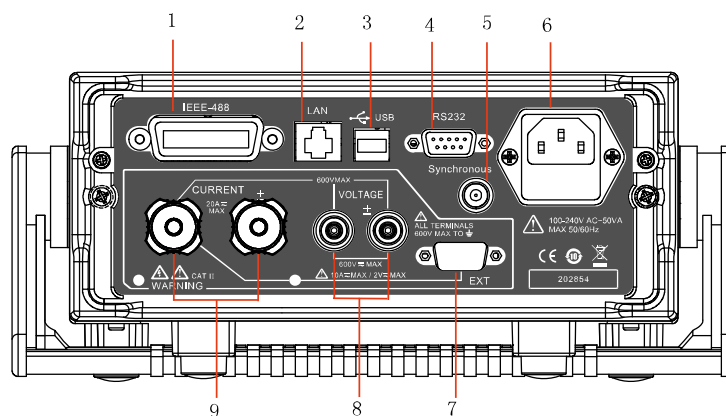

- | | |
|------------------------------------|--|
| 1 GP-IB interface | 2 Ethernet port |
| 3 USB port | 4 RS232 interface |
| 5 External sync signal interface | 6 Power port |
| 7 External sensor connector | 8 Negative voltage input terminals |
| 9 Positive voltage input terminals | 10 Current input terminal protective cover |



Warning: The external sensor interface (as shown in Fig. 7 above) of IT 9120 series power meter is installed with a protective jacket at ex-factory, which should be correctly installed at all circumstances unless an external sensor permitted by ITECH is used.

3.3 Power-on Self-Test

A power-on self-test is a process performed by the instrument to confirm that the instrument purchased by user meets our delivery standards and can function properly during normal use.

Before operation, make sure you've read carefully and understand all the general safety precautions contained in the manual.

WARNING

- Before turning on the instrument, make sure the mains voltage matches the supply voltage so as to prevent burnout of the instrument.
- Always put the mains plug into the grounded socket. Never use an ungrounded wiring board. Before operation, check if the instrument is grounded properly.
- To prevent burnout of the instrument, check the “+” and “-” symbols and maximum voltage and current before connecting the power cord.

The process of power-on self-test is illustrated as follows:

1. Connect the power cord properly and then press **Power** to turn on the instrument.

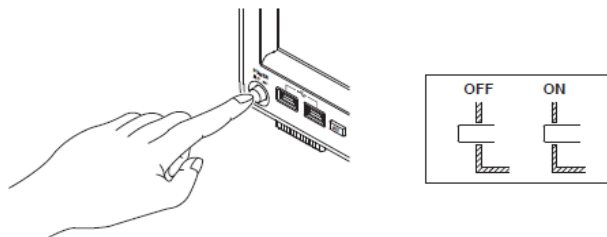

2. At power-on, the instrument model and version information are displayed.



3. When startup completes successfully, the screen displays the following

information:



- Select Menu to access the System Configuration interface. Press SYSTEM to access the SYSTEM INFO interface on which the product model, serial number, computer software version and other information are displayed.



- Select SELF TEST, and the System Self-Test interface will pop up.



- Press **START** to start self-test of the system, including LCD, LED, Display and RAM.

An "OK" symbol following each test item denotes the test result is

acceptable, while a “DONE” symbol denotes the test result is subject to user’s self judgment, such as whether LED displays clearly or not.

- Press **KEY TEST** to check whether keys function properly.

Press all the keys on the front panel; if the icon corresponding to a key shows a black shade, it means the key functions properly.

3.4 Zero Calibration

Zero calibration is a feature used to create a state under which input signal is adjusted to zero through the internal circuit; meanwhile, the electrical level is set to zero.



NOTE

When the measurement range and input filter remain constant for long, the zero level will change with the ambient environment conditions. In this case, zero calibration is recommended.

To make accurate measurements, allow the instrument to warm up for at least 30 min before zero calibration. In addition, make sure the ambient temperature is controlled within the specified range.

The detailed procedures of zero calibration are shown as follows:

1. Connect the power cord properly and then press Power key to turn on the instrument.
2. Select Menu to access the System Configuration interface.

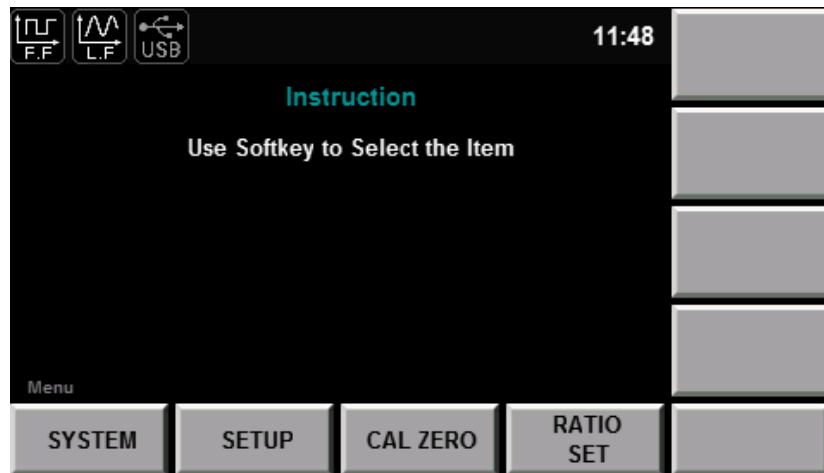

3. Select CAL ZERO->START to start zero calibration.

Wait 1 min for the zero calibration until “Cal Zero is Completed” displays.

3.5 Replacing the Fuse

During normal use of the instrument, you need to replace a blown fuse where necessary by following the procedures below:

1. First pull out the power cord, and then take out the fuse block from the power cord jack with a small screwdriver, as shown below:



2. Have a visual inspection of the fuse to see whether it is burnt out; if yes, replace it with another fuse of the same specification. T1.25A-250V fuse is used for IT9121/IT9121H/IT9121C Power Meter.
3. After replacement, mount the fuse block to the original position, as illustrated below:

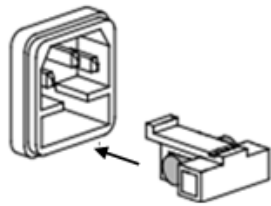

Chapter4 Wiring the Circuit under Measurement

IT9120 series Power Meter is an instrument used to measure electric energy factors (including voltage, current and power) of various electrical appliances. This chapter explains how to wire a typical circuit under measurement.

User may select to wire the circuit either for direct input or using current sensors, depending on the amplitude of the measured voltage or current.

4.1 Precautions when Wiring the Circuit

WARNING

- To prevent electric shock, turn the circuit under measurement off before connection.
- Always put the mains plug into the grounded socket. Never use an ungrounded wiring board. Before connecting the circuit, make sure the electronic load is grounded properly.
- Do not wire a current circuit to the voltage input terminal or a voltage circuit to the current input terminal.
- Strip the insulation covers of the measurement cables so that when they are wired to the input terminals, the conductive parts (bare wires) do not protrude from the terminals. Also, make sure to fasten the input terminal screws securely so that cables do not come loose.
- When connecting measurement cables to the voltage input terminals, only connect measurement cables that have safety rubber terminals that cover their conductive parts. Also, make sure to fasten the input terminal screws securely so that cables do not come loose.
- When connecting cables to the external current sensor input terminals, only connect cables that have safety terminals that cover their conductive parts. Also, make sure to fasten the input terminal screws securely so that cables do not come loose.
- When connecting a measurement cable from an external current sensor to an external current sensor input connector, remove the cables connected to the current input terminals. Also, when the voltage of the circuit under measurement is being applied to the external current sensor input terminals, do not touch the current input terminals. Doing so may impair the measurement accuracy or cause personal injuries.
- When using an external current sensor, make sure to use a sensor that comes in a case. The conductive parts and case should be insulated, and the sensor should have enough dielectric strength for the voltage of the circuit under measurement.

CAUTION

- Use measurement cables satisfying the rated conditions and with dielectric strengths and current capacities that are appropriate for the voltage and current being measured.
- Example: when making measurements on a current of 20A, use copper wires that have a conductive cross-sectional area of 4mm² or greater.

- Attaching a measurement cable to the instrument may cause radio interference in which case the user is required to take proper protective measures.

4.2 Selection of measurement method

According to the size of measured voltage and current, select the method of measurement from the following table. The details of the wiring method instructions, please see the corresponding section.

Current \ Voltage	≤600V(IT9121/IT9121C) ≤1000V (IT9121H)	>600V(IT9121/IT9121C) >1000V (IT9121H)
	≤20A(IT9121/IT9121H) ≤50A(IT9121C)	Direct input (See section 4.3)
>20A(IT9121/IT9121H) >50A(IT9121C)	Current sensor (See section 4.4)	VT/CT method (See section 4.5)

4.3 Wiring the Circuit under Measurement for Direct Input

Under the condition that the measured voltage and current are within the measurement range, when the voltage is 600V or less and the current is 20A or less, you may measure the current and voltage of the circuit for direct input.

There are several patterns of terminal wiring positions shown in the following figures for wiring the voltage input and current input terminals. Depending on the terminal wiring positions, the effects of stray capacitance and the effects of the measured voltage and current amplitudes may become large. To make accurate measurements, refer to the factors below when wiring the voltage input and current input terminals.

- Effects of stray capacitance

When you are measuring a single-phase device, you can minimize the effects of stray capacitance on measurement accuracy by connecting the instrument's current input terminal to the side that is closest to the earth potential of the power supply (SOURCE), as shown below:

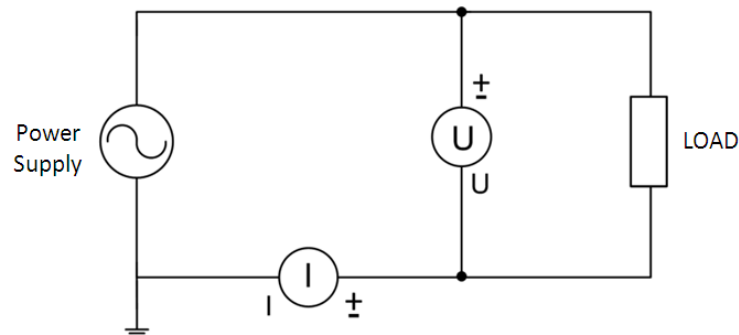

- Effects of the measured voltage and current amplitudes

When the measured current is relatively large, connect the voltage input terminal to the side that is closest to the load. When the measured current

is relatively small, connect the current input terminal to the side that is closest to the load.

When the measured current is relatively large:

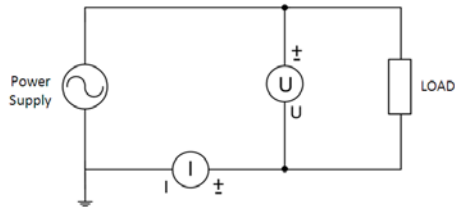

When the measured current is relatively small:

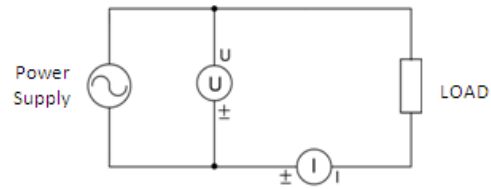

- Voltage input terminals

The terminals are safety banana jacks (female). Only insert a safety terminal whose conductive parts are not exposed into a voltage input terminal.

- Current input terminals

The terminals are binding posts, and the screws are M6. Either wind a wire around a screw or pass a crimped terminal through the screw axis, and then tighten firmly with the terminal knob.

Connection Procedures

The procedures of wiring the circuit when measuring relatively small current are shown as follows:

1. Remove the protective cover over the current input terminals.

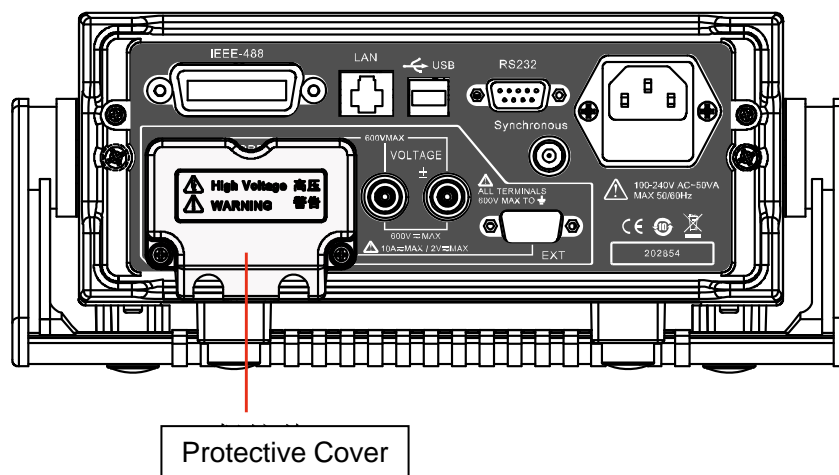

2. The current input and voltage input terminals on the rear panel are shown as follows:

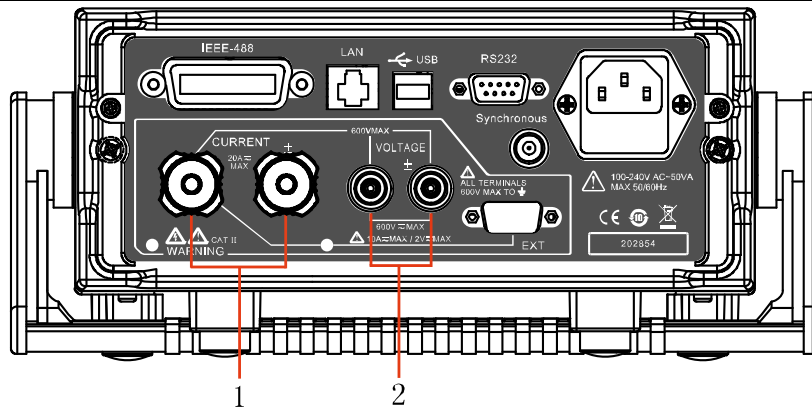

1: Current input terminals 2: Voltage input terminals

3. Connect the circuit under measurement as shown in the wiring diagram below:

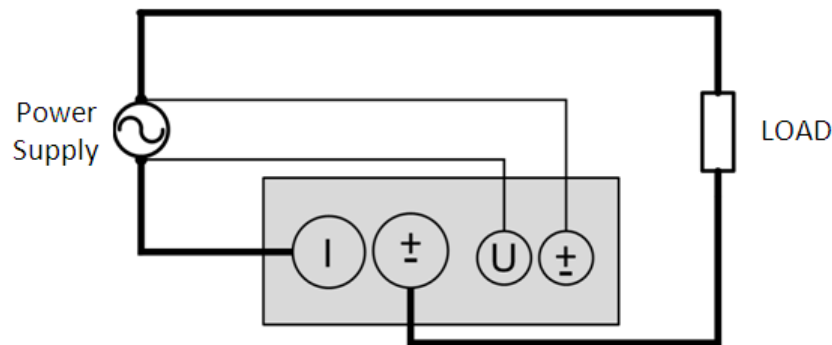

CAUTION

- Use measurement cables satisfying the rated conditions and with dielectric strengths and current capacities that are appropriate for the voltage and current being measured.
- Example: when making measurements on a current of 20A, use copper wires that have a conductive cross-sectional area of 4mm² or greater.
- Attaching a measurement cable to the instrument may cause radio interference in which case the user is required to take proper protective measures.

4. For safety reasons, after you connect the circuit under measurement, attach the protective cover over the current input terminal to prevent contact with the terminal during measurement.

4.4 Wiring the Circuit under Measurement When Using Current Sensors

If the maximum current of the circuit under measurement exceeds the measurement range, you can measure the current of the circuit by connecting a dual-circuit external current sensor to the external current sensor input connector of the instrument.

WARNING

- When using an external current sensor, do not remove the protective cover on the current input terminals to prevent contact with the terminal during measurement.
- Remove the measurement cable connected to the current input terminal. Because the external current sensor input terminal and the current input terminal are connected internally, connecting both terminals simultaneously may result in measurement errors or cause damage to the instrument. Also, when the voltage of the circuit under measurement is being applied to the external current sensor input terminals, do not touch the current input terminals. Doing so may impair the measurement accuracy or cause personal injuries.

The external current sensor connected to the instrument may have either a Constant Range or an Auto Range.

- Constant Range

Model	EXT1	EXT2
IT9121	CF=3: 2.5V, 5V, 10V CF=6: 1.25V, 2.5V, 5V	CF=3: 50mV, 100mV, 200mV, 500mV, 1V, 2V CF=6: 25mV, 50mV, 100mV, 250mV, 0.5V, 1V
IT9121H	CF=3: 2.5V, 5V, 10V CF=6: 1.25V, 2.5V, 5V	CF=3: 50mV, 100mV, 200mV, 500mV, 1V, 2V CF=6: 25mV, 50mV, 100mV, 250mV, 0.5V, 1V
IT9121C	CF=3: 5V, 10V CF=6: 2.5V, 5V	CF=3: 100mV, 250mV, 500mV, 1V, 2.5V CF=6: 50mV, 125mV, 250mV, 0.5V, 1.25V

- Auto Range

The measurement range can switch automatically depending on the amplitude of input signal.

External Sensor Interface

Each pin of the external sensor interface is described as follows.



external sensor interface instruction

Pin	Description
1	NC
2	OverLoad (output pin)
3	NC
4	GND
5	EX2
6	NC
7	NC
8	GND
9	EX1

Connection Procedures

Connect an external current sensor with a measurement range appropriate for the amplitude of measured current. When the measured current is 100A, select a current sensor with an output voltage not exceeding this limit.

Assuming that the output voltage generated by 1A current flowing the current

sensor is X mV (Conversion Ratio), the maximum voltage generated by 100A flowing a 10mV/A current sensor is $10\text{mV/A} \times 100\text{A} = 1\text{V}$. Therefore, the measurement range of the current sensor must be EXT2, and the Conversion Ratio is set at 10mV/A.

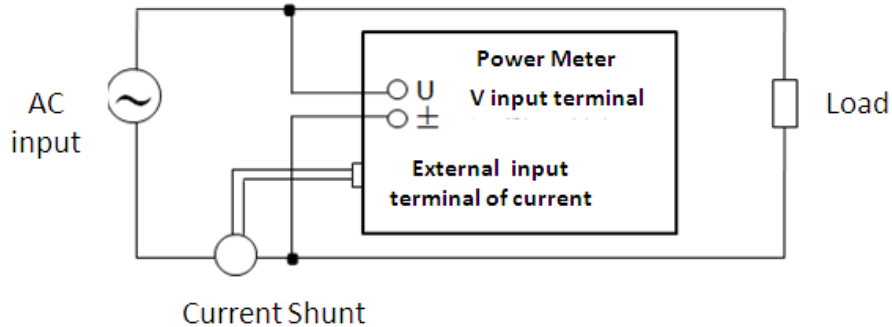

1. Connect the power supply, external current sensor, electronic load and Power Meter as shown in the wiring diagram.
2. Turn on the power meter.
3. Select **Menu > SETUP > EXT SEN SET** to access the External Sensor Setup interface.



4. First press \blacktriangle \blacktriangledown to select ExSENSOR2. Then press ON to turn on the external current sensor and set the Conversion Ratio at 10mV/A using the knob.



5. Press Enter to save the settings.
6. Press Esc to exit the settings; and press A-RANGE on the Integ page to query the settings.

4.5 Wiring the Measurement Circuit with VT/CT

When the maximum voltage and current of the measured object exceed the maximum measurement range of the instrument, you can measure parameters with the external voltage transformer (VT) and current transformer (CT).

- When the maximum voltage value exceeds 600V, connect the external VT and connect the voltage input terminals to the secondary side terminals. (IT9121/IT9121C)
- When the maximum voltage value exceeds 1000V, connect the external VT and connect the voltage input terminals to the secondary side terminals. (IT9121H)
- When the maximum current value exceeds 20A, connect the external CT and connect the current input terminals to the secondary side terminals. (IT9121/IT9121H)
- When the maximum current value exceeds 50A, connect the external CT and connect the current input terminals to the secondary side terminals. (IT9121C)

WARNING

- When connecting a measurement cable from CT to the current input terminals, remove the cables connected to the external current sensor terminals. Also, when the voltage of the circuit under measurement is being applied to the current input terminals, do not touch the external current sensor input terminals. Doing so may impair the measurement accuracy or cause personal injuries.
- About the VT or CT usage instructions, please comply with the instructions.

Ratio Function

When measuring voltage, current and power of DUT with VT/CT, connect the secondary side output terminals of VT/CT to power meter input terminals, user can set ratio value of VT/CT. Power meter interface displays the value which multiplied by a ratio factor.



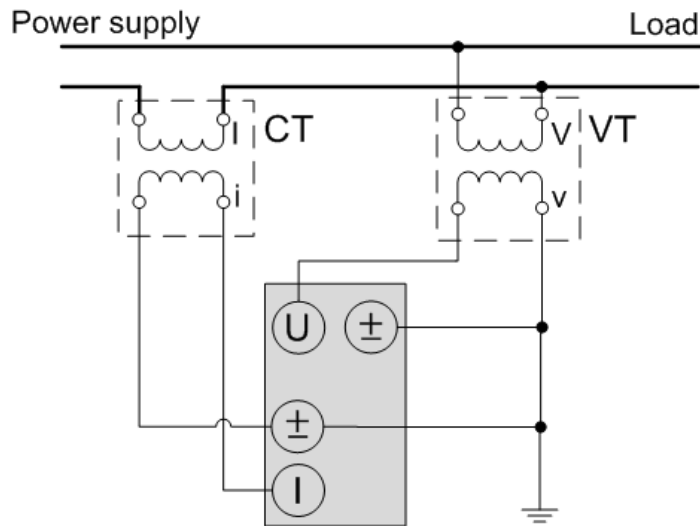
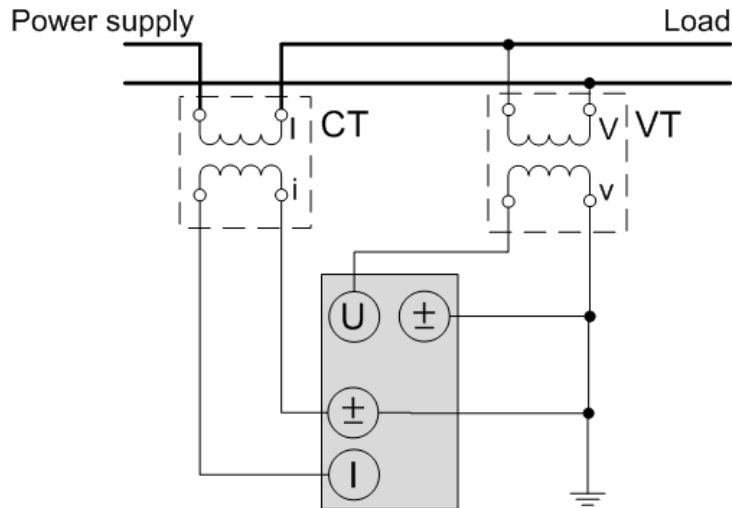

Connection Method

The connection methods are as follows, you can choose any one of them. To ensure safety, please connect the VT/CT secondary side public port (+/-) to the ground.

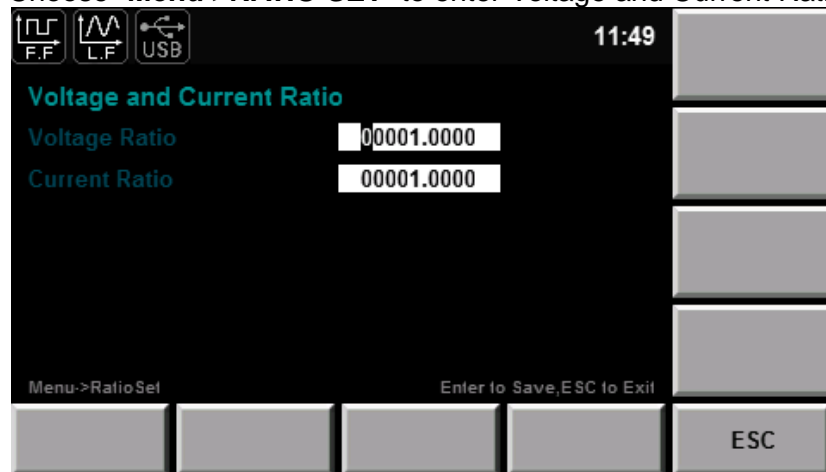

1. Connect the power supply, VT, CT, load and power meter according to the circuit diagram.
2. Turn on the power meter.
3. Choose “**Menu >RATIO SET**” to enter Voltage and Current Ratio page.



4. Press   key to choose “Voltage Ratio” or “Current Ratio”. Use rotary knob and   key to set VT/CT ratio value.
5. Press **[Enter]** key to save the configuration.

6. Press [ESC] key to exit the configuration page..

4.6 Instructions of IT-E185 Fixture

IT-E185 fixture is used in AC input power consumption of AC-DC adapter, IT9120 series is connected in serial to the adapter and electric supply.

Connection Method

Connect DUT to the front panel of IT-E185 fixture, as shown in the following figure:

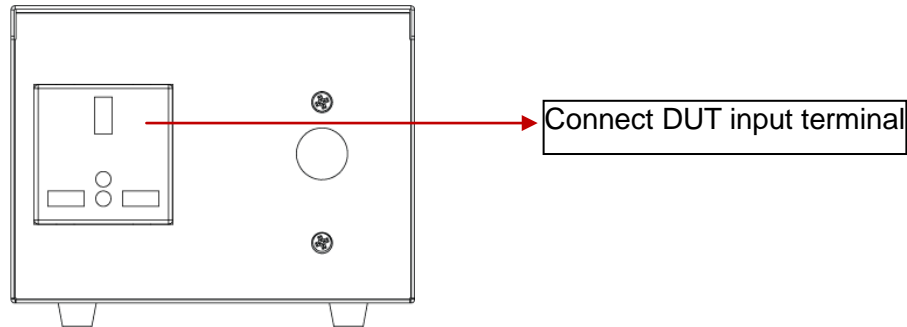

Connect power meter to the rear panel of IT-E185 fixture, as shown in the following figure:

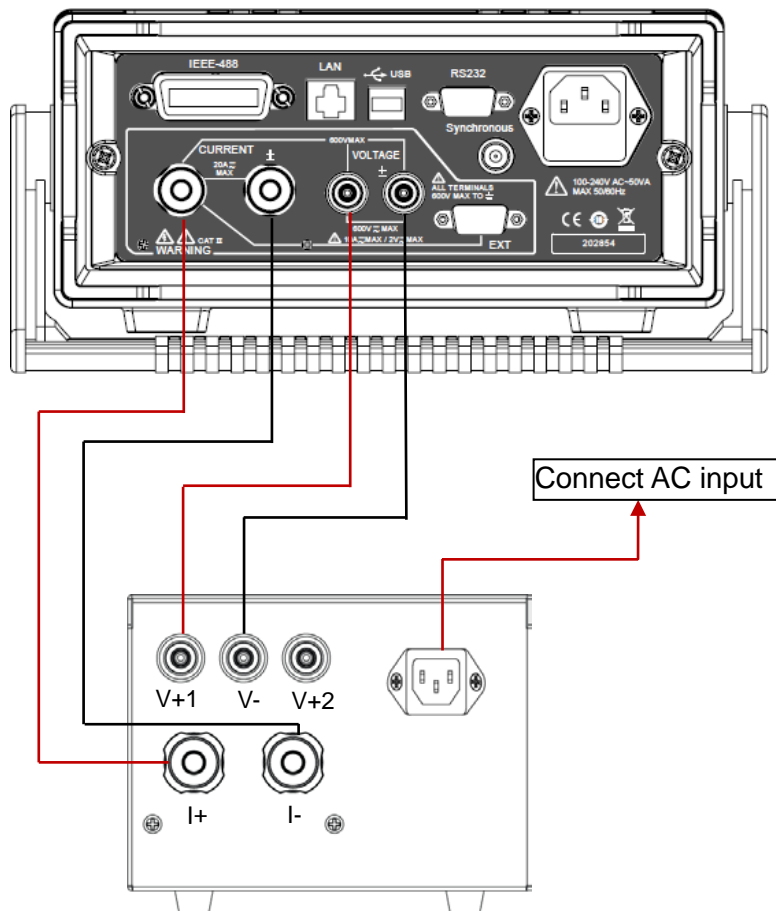

Appendix

Specifications of Red and Black Test Lines

ITECH provides you with optional red and black test lines, which individual sales and you can select for test. For specifications of ITECH test lines and maximum current values, refer to the table below.

Model	Specification	Cross section	Length
IT-E301/10A	10A	-	1m
IT-E301/30A	30A	6mm ²	1.2m
IT-E301/30A	30A	6mm ²	2m
IT-E301/60A	60A	20mm ²	1.5m
IT-E301/120A	120A	50mm ²	2m
IT-E301/240A	240A	70mm ²	1m
IT-E301/240A	240A	70mm ²	2m
IT-E301/360A	360A	95mm ²	2m

For maximum current of AWG copper wire, refer to table below.

AWG	10	12	14	16	18	20	22	24	26	28
The Maximum current value(A)	40	25	20	13	10	7	5	3.5	2.5	1.7

Note: AWG (American Wire Gage), it means X wire (marked on the wire). The table above lists current capacity of single wire at working temperature of 30°C. For reference only.

Contact Us

Thanks for purchasing ITECH products. In case of any doubts, please contact us as follows:

1. Visit ITECH website:www.itechate.com
2. Select the most convenient contact method, for further information.